

Office of the Chief General Manager Telecom  
Odisha Telecom Circle, S & M Cell, 2<sup>nd</sup> Floor,  
C.N.I. Bhawan, Ashok Nagar, Unit - 2,  
Bhubaneswar - 751009.



भारत संचार निगम लिमिटेड  
BHARAT SANCHAR NIGAM LIMITED

a/c

Ref No: Tender OR/SM/CM/RETAILER-BOARD/18-19  
Dated 24th JULY 2018

### **TECHNICAL SPECIFICATION & DESIGN**

This is for information of all the prospective bidders for the Original tender as above (Ref No: OR/SM/CM/RETAILER-BOARD/18-19 Dated 6<sup>th</sup> July 2018) that the following **DETAILS OF THE SPECIFICATION & THE DESIGN** is being made as below for the selection of bidders for the supply and installation of Retailer Boards.

The bidders are advised to take in to account of the following details before submission of their bid against the tender as referred above. If any bidder has already submitted its/his/her bid, then it is to be resubmitted taking in to account of the following.

Type of Work	DISTRIBUTION OF QUANTITY
<b>NON-LIT RETAILER BOARDS</b>	<b>SECTION – 1 (PART-A), Clause-9 at Page-3.</b> Rs.590/- (Rupees Five hundred Ninety Only) (Non-refundable). The cost of tender paper should be submitted in shape of crossed DD/BC drawn after the date of publication of NIT on any Nationalized/Scheduled Bank in favour of Accounts Officer (A & P), BSNL, O/o CGM, BSNL, Bhubaneswar payable at Bhubaneswar. <b>The scanned copy of the above DD/BC towards cost of tender document should be uploaded in E-tendering portal of M/s ITI.</b>  <b>Details of the Specifications &amp; DESIGN of CSC STANDY &amp; DRIVE-WAY BOARD: At Annexure-A</b>

**(The DESIGNS of the CSC STANDESS & DRIVE-WAY Boards are attached as Annx-A)**

For convenience, the revised ~~the~~ tender document along with the format has been up loaded on the website <http://www.odisha.bsnl.co.in/newtender.php?tenderdistrict=Orissa>.

**NOTE: Please Sign & submit these documents along with the original tender while applying in the Tender.**

AGM (Marketing)  
O/o GM (CM S & M), BSNL, Odisha  
24/7/18

**ITEM No-5: CSC STANDEES DESIGN:**

**(INDICATIVE SIZE of the STANDEE)**

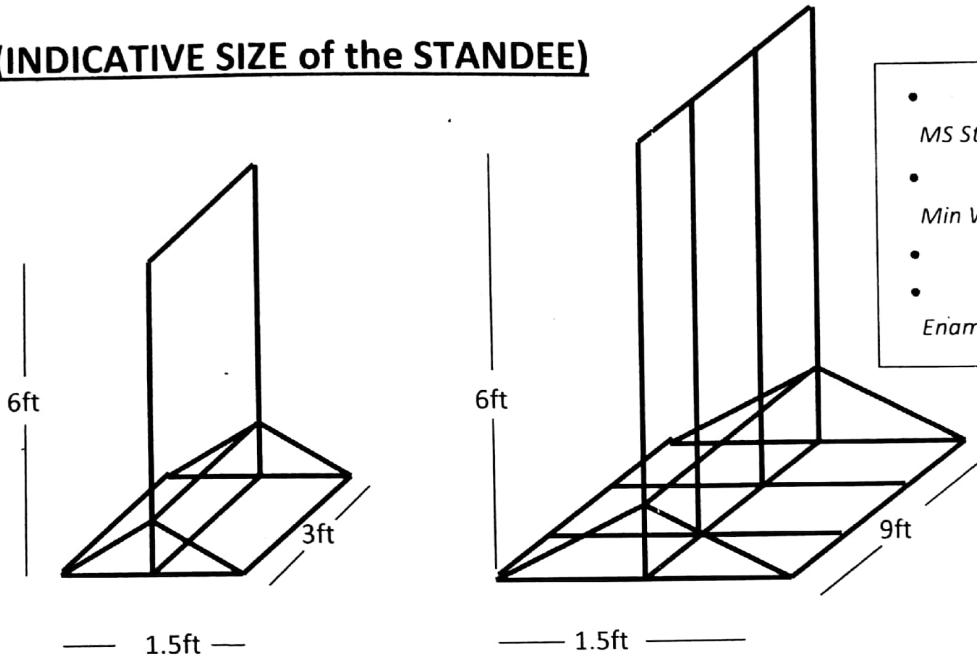

- **FRAME** are of 1.5" X 1.5" MS Steel. Min Weight 9.6KG/20ft.
- **LEGS** are of 2" X 2" MS Steel Min Weight 19KG/20ft.
- Thickness: Min 2mm.
- Coated with Red-Oxide & Enamel.

- Additional sets of LEGS required for every 3ft.
- For length 3ft-2Legs, For length 6ft-3Legs, For length 9ft-4Legs and so on.

**ITEM No.-3: DRIVE-WAY BOARDS DESIGNS:**

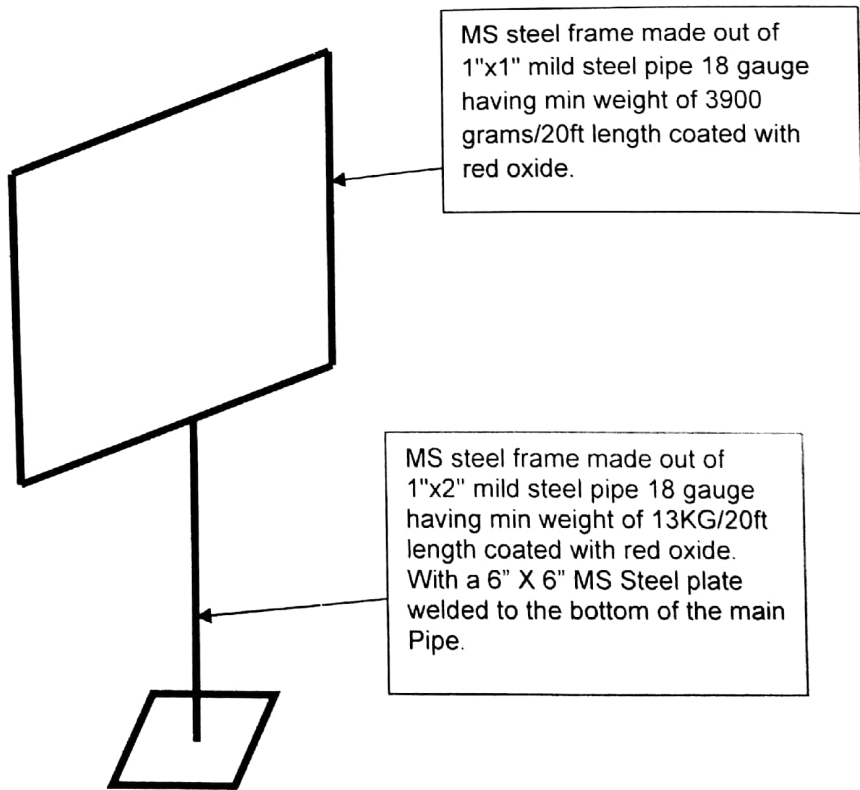

MS steel frame made out of 1"x1" mild steel pipe 18 gauge having min weight of 3900 grams/20ft length coated with red oxide.

MS steel frame made out of 1"x2" mild steel pipe 18 gauge having min weight of 13KG/20ft length coated with red oxide. With a 6" X 6" MS Steel plate welded to the bottom of the main Pipe.